



# Data Logger Specification

2022-01-04

## Contents

Changelog	2
1 Data Logger	2
2 Connectors	3
3 Mechanical Drawings	4
4 Accessing the Data Logger	4



# Changelog

Section	Version	Change
	V0.1	Preliminary Datasheet

## 1 Data Logger

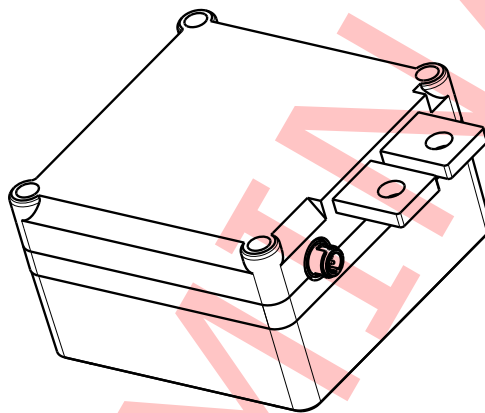

(a) Data Logger (DL) overview

A DL according to this specification will be used and provided by the officials as official measuring system according to EV4.6 and T14.3.

The DL must be mounted according to EV4.6. It must be properly fastened and mounted at a location where it is protected from water.

Its housing is of the type "Bopla Euromas II ET212" with outer dimensions of 100 mm x 100 mm x 75 mm (height might be smaller) and a weight of 800 g.

CAD-data of the DL can be found on the competition website<sup>1</sup>.

The DL must be supplied by a voltage of 12 VDC to 70 VDC. It draws a maximum power of 10W. It must be reasonably fused in the supply wiring.

The CAN bus interface operates on a data rate of 1 Mbit/s and is not terminated internally.

The CAN message layout can be obtained from a dbc-file provided on the competition website<sup>1</sup>.

The Ethernet interface is according to the 100BASE-TX standard and requires a cable at least adhering to ISO/IEC 11801 Cat 5 with an RJ-45 connector. It must be easily accessible for data download. It is recommended to use a RJ45 - M12 d-code cable<sup>2</sup>.

The sensor used by the DL is an Isabellenhütte IVT-500-U3-TOI-CAN2-12<sup>3</sup>.

The DL must be mounted via 3M™ Dual Lock™.

The pinout of the connectors has to be according to Tables 2 and 3.

<sup>1</sup><https://formulastudent.de/rules>

<sup>2</sup>[https://b2b.harting.com/ebusiness/en\\_us/RJ45-M12-d-code-str-AWG22-7-PUR-3-0m/09486896018030](https://b2b.harting.com/ebusiness/en_us/RJ45-M12-d-code-str-AWG22-7-PUR-3-0m/09486896018030)

<sup>3</sup><https://isabellenhuetten.de/en/precision-measurement/standard-products/ivt-series>



## 2 Connectors

### Busbar with 8.1 mm hole(DL-side)

- TS- in current path
- Must be connected fulfilling EV 4.6.4

### Binder 09 0981 00 046 (DL-side)

- TS+ voltage measurement
- Must be connected fulfilling EV 4.6.5
- Binder 99 0980 100 04 (vehicle-side)

### Harting 21 03 321 3401 (DL-side)

- Power and CAN interface
- Must power the DL according to EV 4.6.6.
- Can be connected to a vehicle CAN bus to obtain status messages.
- Teams are advised to check the status messages, as they provide the status of the data logger.
- Missing data due to not checking the status messages will be treated as a fault of the team.
- Status messages are sent with a frequency of 50 Hz.
- Status messages contain maximum values (Voltage, Current, Power) of the respective time interval.
- Status messages are provided as a general reference only, only the data stored on the DL will be used for scoring.
- [DV ONLY] CAN Interfaces must be connected to the bus shared with the Remote Emergency System (RES).
- Harting TBD (vehicle-side)

Pin	Description
1	LV+
2	LV- (GND)
3	CANH
4	CANL

Table 2: DL side Power & CAN Connector (Harting 21 03 321 3401)

### Harting 21 03 381 4440 (DL-side)

- 100 Mbit/s Ethernet interface used for connecting to the DL
- A cable must be provided long enough to reach a Data Logger Download Station (DLDS) that is 2 m away from the vehicle.
- A standard Ethernet RJ45 Plug must be provided for the the download station.
- Recommended cable: Harting 09 48 689 6018 030

Pin	Description
1	TX+
2	RX+
3	TX-
4	RX-

Table 3: DL side Ethernet connector (Harting 21 03 381 4440)



Status	LED A	LED B
Idle, not logging	TBD	TBD
Logging	TBD	TBD
Error	TBD	TBD

Table 4: DL status LEDs

### 3 Mechanical Drawings

The dimension can be seen in the following Figures:

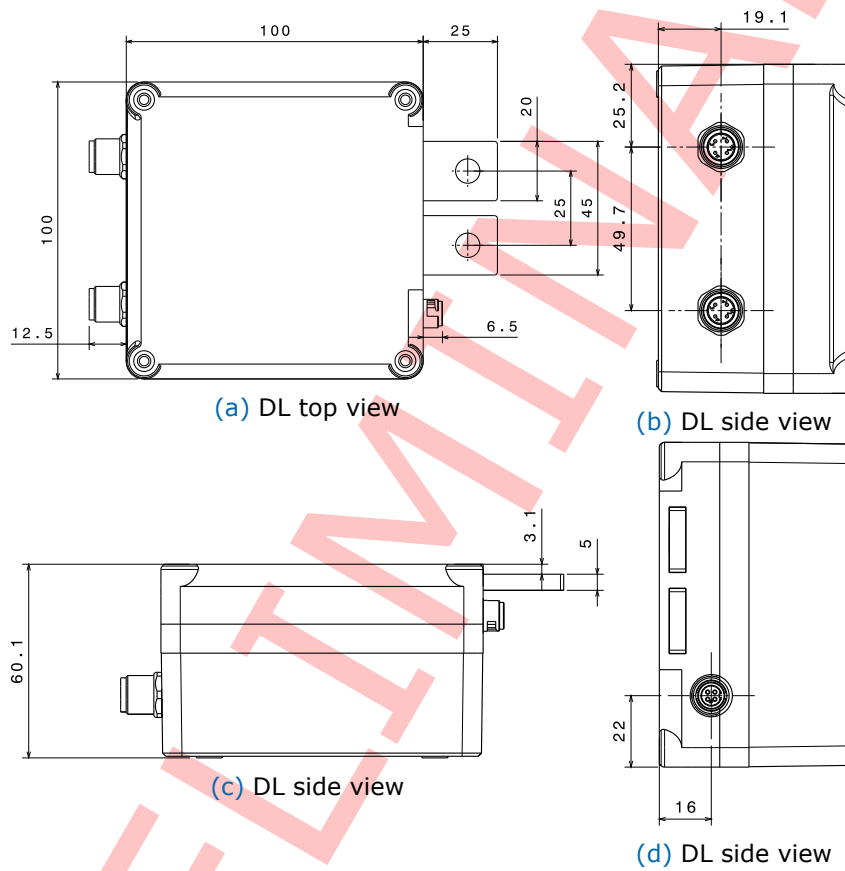

Figure 2: DL drawings (dimension in mm)

### 4 Accessing the Data Logger

TBD